

# Catalog

AUTOMATIC WELDING  
TORCHES

2023



PRODUCT



**EDR** torches<sup>®</sup>  
Evolution Design Robotics

# AUTOMATIC series

EDRtorches automatic torches always offer high performance, differentiating themselves from other automatic torches because of their high quality replacement used in robot systems, designed with high durability standards, lower maintenance costs and lower number of repairs.

Torches designed for fixed applications, with various configurations in degrees and available in liquid and gas-cooled systems, both systems use the same compatible replacement to avoid duplicating stocks. You can choose any length of cables from the standards to custom half.

If there is no standard configuration, tell us the requirements you need and we will design the torch under your requirements.

EDRtorches engineering team is looking for solutions for their welding systems.



## AUTOMATIC WELDING TORCHES

EDRtorches, S.L.  
Calle Miguel Angel Blanco 28. 46138 -  
Rafelbuñol - Valencia Spain.

[www.edrtorches.com](http://www.edrtorches.com)  
[info@edrtorches.com](mailto:info@edrtorches.com)  
Tel. 0034 963 558 893

## Index

### Automatic welding torches

Torch MIG/MAG gas AUT 42G 4 Pag.

Torch MIG/MAG liquid AUT 52W 6 Pag.

Torch MIG/MAG liquid AUT 52PLUS 8 Pag.



MIG/MAG





**Welding process:**  
MIG/MAG, GMAW, 131,135  
Technical data according to IEC60974-7

- Gas
- 300 A - CO2 100%
- 250 A - Mix M21 (ISO 14175) 100%
- Ø1.0-1.2 mm
- 10-18 l/min

The capacity will be reduced by 35% with pulsed arc.

The line of automatic torches adapts perfectly to all the standard automatic systems, with advantages superior to the standard ones.

The gas cooled version supports work cycles much higher than the most standard versions of the market. Larger nozzle and its M10 contact tips and large length make it behave perfectly in automatic systems.

STANDARD CONFIGURATION

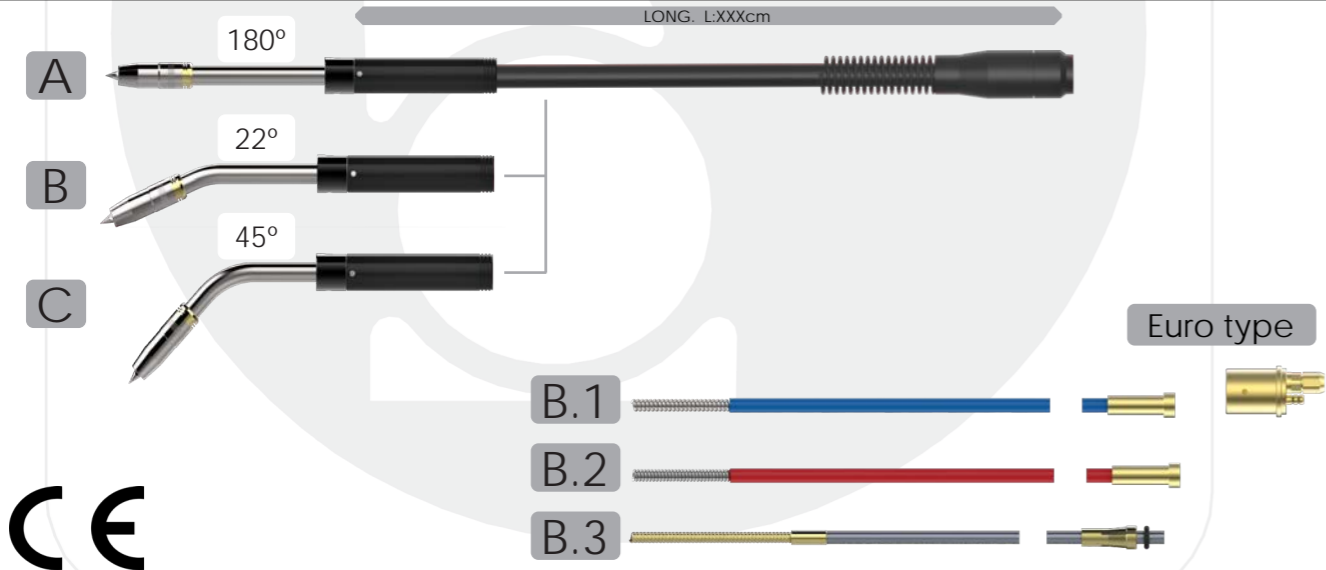

Pos.	TYPE	CODE	Min. Q.
A	Automatic torch AUT42G-180° gas-Euro type	M98 1xxx 00	1
B	Automatic torch AUT42G-22° gas-Euro type	M98 1xxx 22	1
C	Automatic torch AUT42G-45° gas-Euro type	M98 1xxx 45	1
B.1	Guide blue L2600xØ4.6xØ1.5mm (0.8-1.0mm)-Euro	M99SR02B	1
	Guide blue L3600xØ4.6xØ1.5mm (0.8-1.0mm)-Euro	M99SR03B	1
	Guide blue L4600xØ4.6xØ1.5mm (0.8-1.0mm)-Euro	M99SR04B	1
B.2	Guide red L2600xØ4.6xØ2.0mm (1.0-1.2mm)-Euro	M99SR02R	1
	Guide red L3600xØ4.6xØ2.0mm (1.0-1.2mm)-Euro	M99SR03R	1
	Guide red L4600xØ4.6xØ2.0mm (1.0-1.2mm)-Euro	M99SR04R	1
B.3	Guide for Alum L2700xØ4.5xØ2.5mm (1.2-1.6mm)-Euro	M99SA102	1
	Guide for Alum L3700xØ4.5xØ2.5mm (1.2-1.6mm)-Euro	M99SA103	1

enDS-AUT42G-02

SPARE PARTS



Pos.	TYPE	CODE	Min. Q.
1	Nozzle L76xØ15.5 mm	R10 0011	2
	Nozzle L76xØ13 mm	R10 0012	2
	Nozzle L79xØ15.5 mm	R10 00211	2
1.1	Insulator nozzle L35XØ19.5 mm	R10 0002	2
2	Contact tip M10 1.0 mm Cu-BICOMP	R10 0400 10	5
	Contact tip M10 1.2 mm Cu-BICOMP	R10 0400 12	5
	Contact tip M10 1.0 mm CuCrZr	R10 0401 10	10
	Contact tip M10 1.2 mm CuCrZr	R10 0401 12	10
3	Diffuser L26xØ18.5 mm M10	R12 0013	2
4	Insulator neck L11XØ18.5 mm	R12 0308	2
5	Oring neck Ø23 mm	R10 0401	10

STANDARD MEASURES

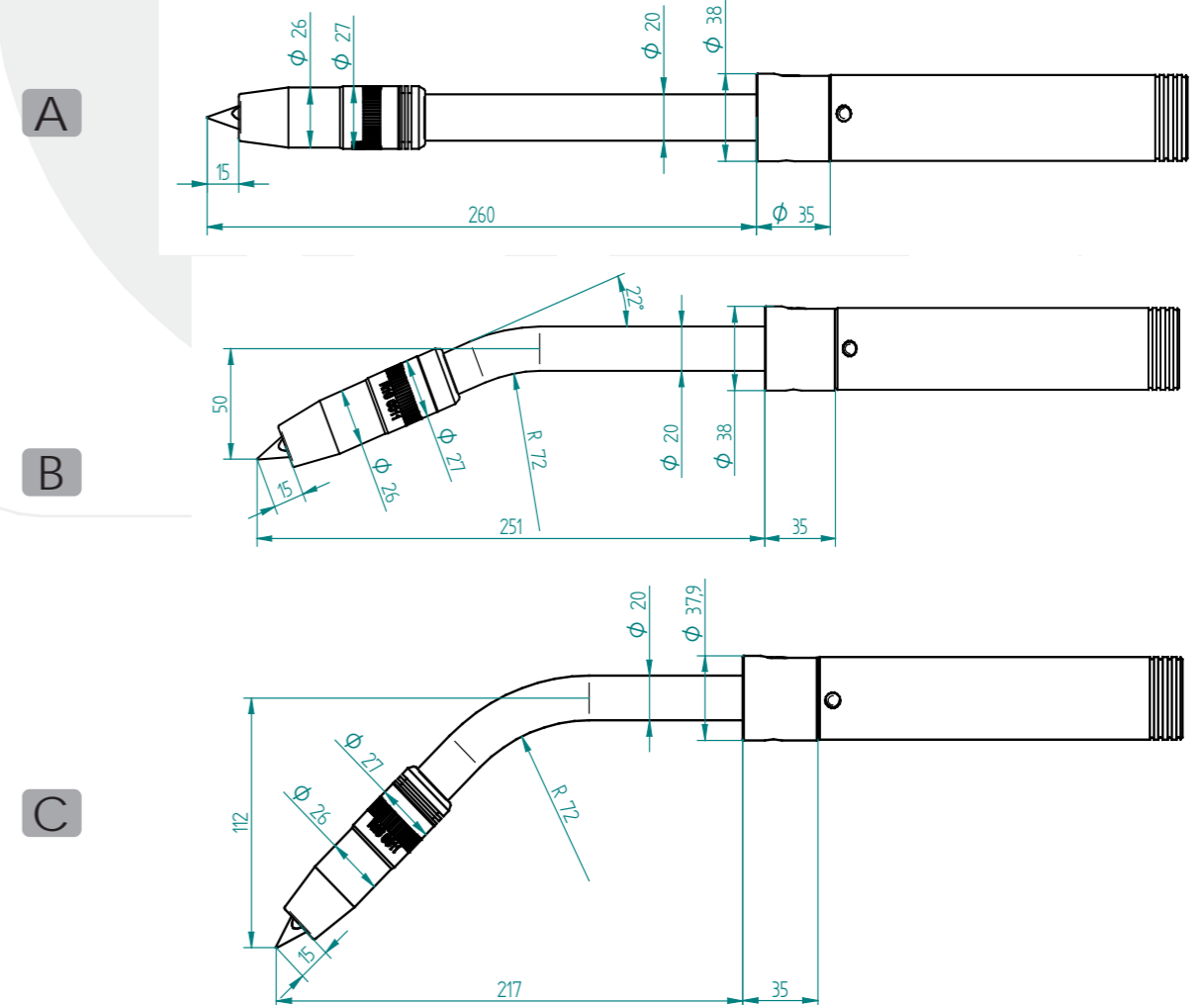



**Welding process:**  
MIG/MAG, GMAW, 131,135  
Technical data according to IEC60974-7

- Liquid
- 500 A - CO2 100%
- 400 A - Mix M21 (ISO 14175) 100%
- Ø1.0-1.6 mm
- 10-18 l/min

The capacity will be reduced by 35% with pulsed arc.

The line of automatic torches adapts perfectly to all the standard automatic systems, with advantages superior to the standard ones.

The liquid cooled version supports work cycles much higher than the most standard versions of the market. Larger nozzle and its M10 contact tips and large length make it behave perfectly in automatic systems.

STANDARD CONFIGURATION

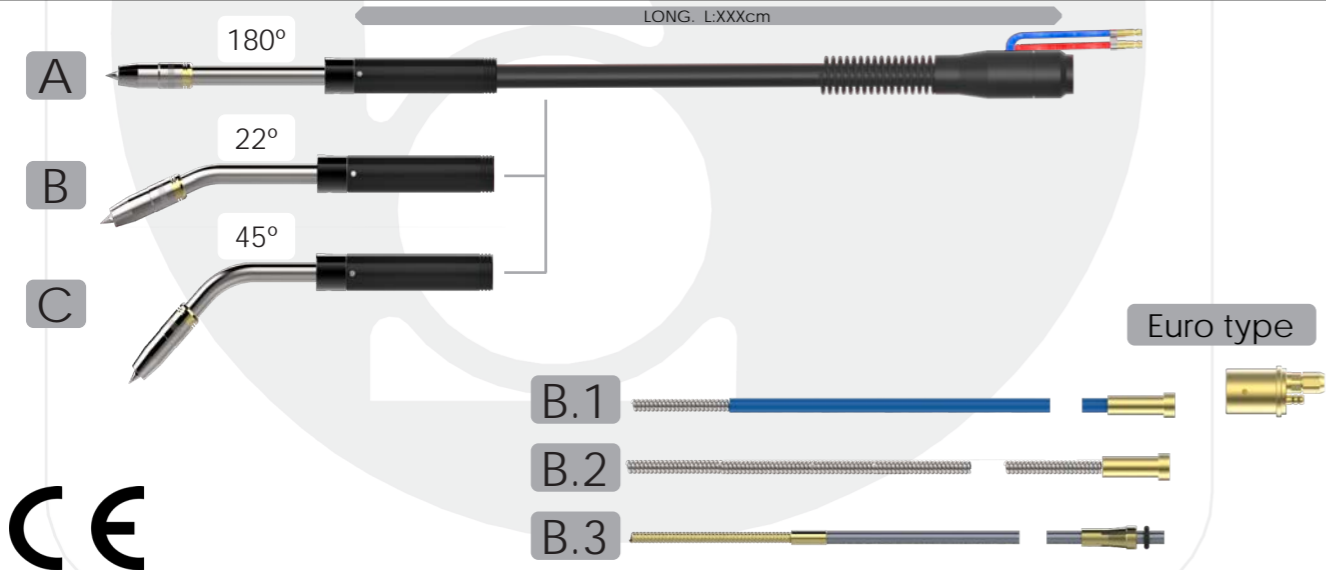

Pos.	TYPE	CODE	Min. Q.
A	Automatic torch AUT52W-180° liquid-Euro type	M99 1xxx 00	1
B	Automatic torch AUT52W-22° liquid-Euro type	M99 1xxx 22	1
C	Automatic torch AUT52W-45° liquid-Euro type	M99 1xxx 45	1
B.1	Guide blue L2600xØ4.6xØ1.5mm (0.8-1.0mm)-Euro	M99SR02B	1
	Guide blue L3600xØ4.6xØ1.5mm (0.8-1.0mm)-Euro	M99SR03B	1
	Guide blue L4600xØ4.6xØ1.5mm (0.8-1.0mm)-Euro	M99SR04B	1
B.2	Guide nude L2600xØ4.6xØ2.2mm (1.2-1.6mm)-Euro-HD	M45SR02	1
	Guide nude L3600xØ4.6xØ2.2mm (1.2-1.6mm)-Euro-HD	M45SR03	1
	Guide nude L4600xØ4.6xØ2.2mm (1.2-1.6mm)-Euro-HD	M45SR04	1
B.3	Guide for Alum L2700xØ4.5xØ2.5mm (1.2-1.6mm)-Euro	M99SA102	1
	Guide for Alum L3700xØ4.5xØ2.5mm (1.2-1.6mm)-Euro	M99SA103	1

enDS-AUT52W-02

SPARE PARTS



Pos.	TYPE	CODE	Min. Q.
1	Nozzle L76xØ15.5 mm	R10 0011	2
	Nozzle L76xØ13 mm	R10 0012	2
	Nozzle L79xØ15.5 mm	R10 00211	2
1.1	Insulator nozzle L35XØ19.5 mm	R10 0002	2
2	Contact tip M10 1.0 mm Cu-BICOMP	R10 0400 10	5
	Contact tip M10 1.2 mm Cu-BICOMP	R10 0400 12	5
	Contact tip M10 1.6 mm Cu-BICOMP	R10 0400 16	5
	Contact tip M10 1.0 mm CuCrZr	R10 0401 10	10
	Contact tip M10 1.2 mm CuCrZr	R10 0401 12	10
	Contact tip M10 1.6 mm CuCrZr	R10 0401 16	10
3	Diffuser L26xØ18.5 mm M10	R12 0013	2
4	Insulator neck L11XØ18.5 mm	R12 0308	2
5	Oring neck Ø23 mm	R10 0401	10

STANDARD MEASURES

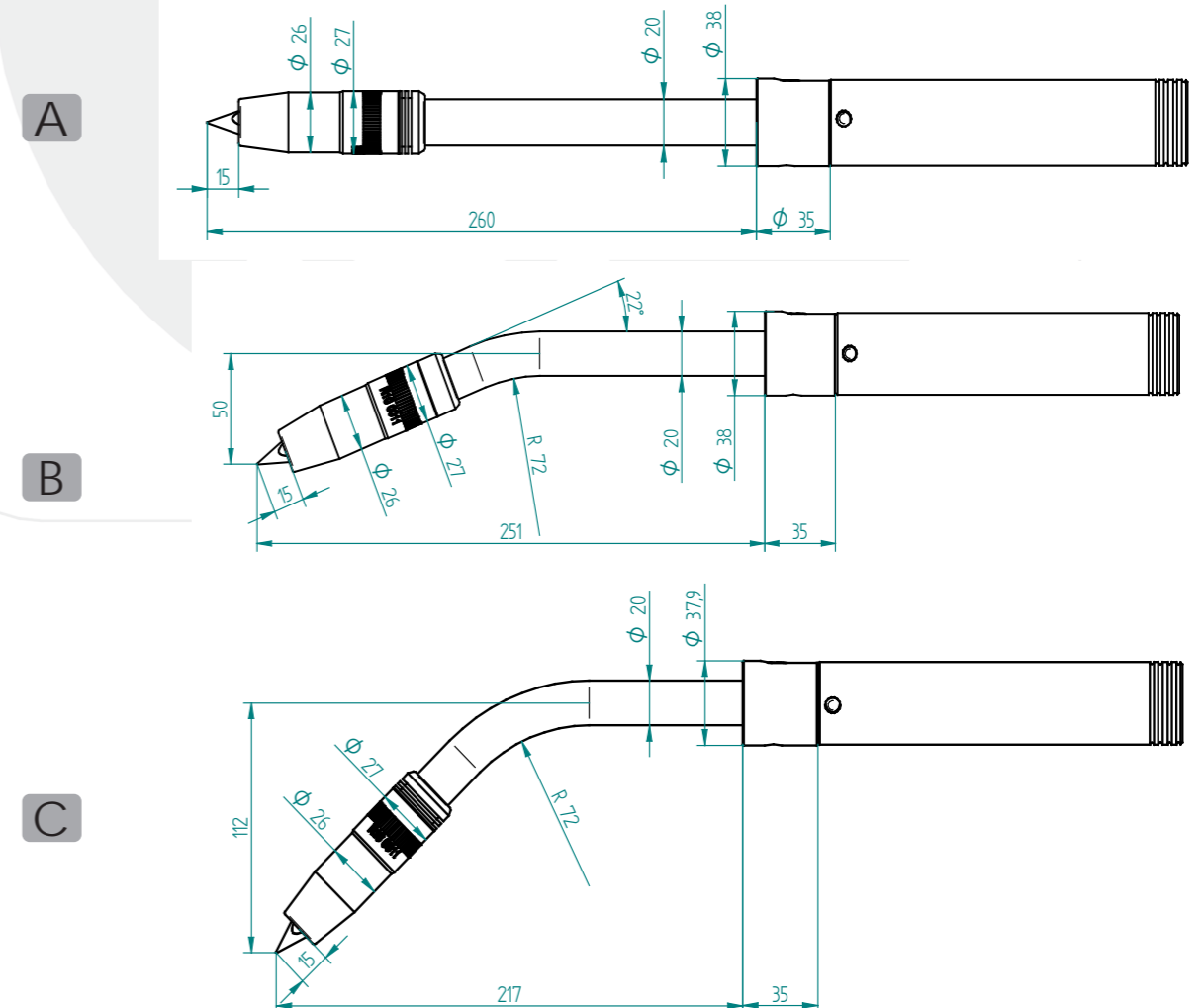



Welding process:  
MIG/MAG, GMAW, 131,135  
Technical data according to IEC60974-7

- Liquid
- 550 A - CO2 100%
- 450 A - Mix M21 (ISO 14175) 100%
- Ø1.0-1.6 mm
- 10-18 l/min

The capacity will be reduced by 35% with pulsed arc.

The line of automatic torches adapts perfectly to all the standard automatic systems, with advantages superior to the standard ones.

The PLUS refrigerated version has a double cooling circuit independently, with much greater cooling in the nozzle. The larger M10 contact tips and its large length make it behave perfectly in automatic systems.

STANDARD CONFIGURATION

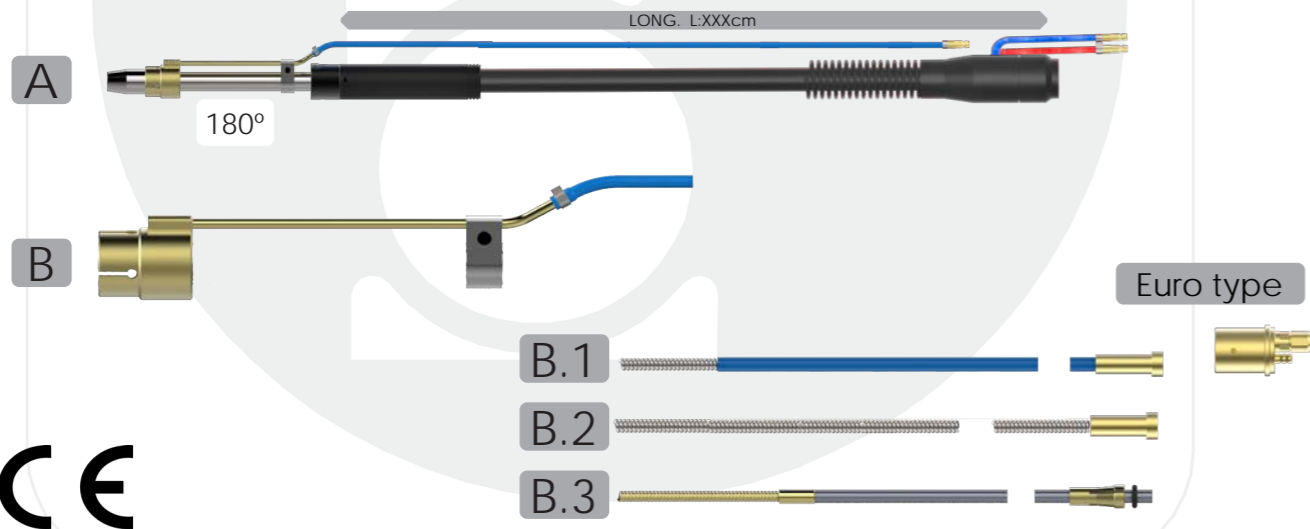

Pos.	TYPE	CODE	Min. Q.
A	Automatic torch AUT52PLUS-180° liquid-Euro type	M99 1xxx 00P	1
B	X2 refrigeration system	R11 6000	1
B.1	Guide blue L2600xØ4.6xØ1.5mm (0.8-1.0mm)-Euro	M99SR02B	1
	Guide blue L3600xØ4.6xØ1.5mm (0.8-1.0mm)-Euro	M99SR03B	1
	Guide blue L4600xØ4.6xØ1.5mm (0.8-1.0mm)-Euro	M99SR04B	1
B.2	Guide nude L2600xØ4.6xØ2.2mm (1.2-1.6mm)-Euro-HD	M45SR02	1
	Guide nude L3600xØ4.6xØ2.2mm (1.2-1.6mm)-Euro-HD	M45SR03	1
	Guide nude L4600xØ4.6xØ2.2mm (1.2-1.6mm)-Euro-HD	M45SR04	1
B.3	Guide for Alum L2700xØ4.5xØ2.5mm (1.2-1.6mm)-Euro	M99SA102	1
	Guide for Alum L3700xØ4.5xØ2.5mm (1.2-1.6mm)-Euro	M99SA103	1

enDS-AUT52PLUS-02

SPARE PARTS

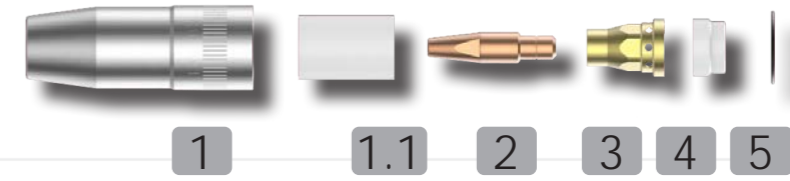

Pos.	TYPE	CODE	Min. Q.
1	Nozzle L76xØ15.5 mm	R10 0011	2
	Nozzle L76xØ13 mm	R10 0012	2
	Nozzle L79xØ15.5 mm	R10 00211	2
1.1	Insulator nozzle L35XØ19.5 mm	R10 0002	2
2	Contact tip M10 1.0 mm Cu-BICOMP	R10 0400 10	5
	Contact tip M10 1.2 mm Cu-BICOMP	R10 0400 12	5
	Contact tip M10 1.6 mm Cu-BICOMP	R10 0400 16	5
	Contact tip M10 1.0 mm CuCrZr	R10 0401 10	10
	Contact tip M10 1.2 mm CuCrZr	R10 0401 12	10
	Contact tip M10 1.6 mm CuCrZr	R10 0401 16	10
3	Diffuser L26xØ18.5 mm M10	R12 0013	2
4	Insulator neck L11XØ18.5 mm	R12 0308	2
5	Oring neck Ø23 mm	R10 0401	10

STANDARD MEASURES

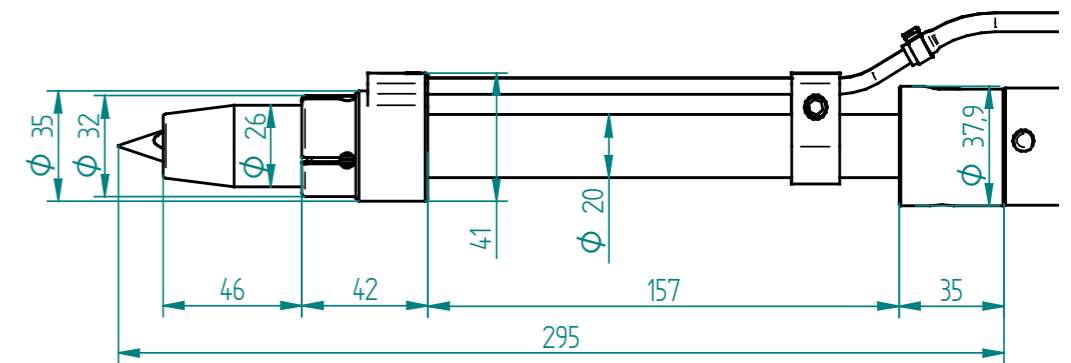

## Automatic welding torches



EDRtorches, S.L.  
Calle Miguel Angel Blanco 28. 46138  
Rafelbuñol - Valencia Spain.  
[www.edrtorches.com](http://www.edrtorches.com)  
[info@edrtorches.com](mailto:info@edrtorches.com)  
Tel. 0034 963 558 893